

# SCHVB-40.5(P)/T

户内手车式真空断路器

Handcart Type Indoor Vacuum Circuit Breaker



## 适用范围

### Application

SCHVB-40.5(P)/T(3AV3) 系列户内手车式真空断路器适用于三相交流 50Hz、40.5kV 系统中，可供工矿企业、发电厂及变电站作为分合负荷电流、过载电流故障电流之用，并适用于频繁操作场合。本断路器采用上下布置结构，有效地降低断路器的深度。并采用复合绝缘结构、三相灭弧室和相联带电体由三只独立的环氧树脂绝缘罩壳相隔离，采用复合绝缘结构之后，断路器满足正常运行条件下的空气距离和爬距要求，并有效地减少了断路器的体积，主回路真空灭弧室和动静导电联接安装在绝缘筒内，使相间仅为 300mm。主回路电气连接全部采用固定连接具有很高的可靠性。

SCHVB-40.5(P)/T (3AV3)-series handcart type indoor vacuum circuit breaker for three-phase AC 50Hz, 40.5KV power system, for industrial and mining enterprises, power plants and substations as the division and load current, overload current fault current purposes, and occasions for frequent operation.

The circuit breaker arrangement with upper and lower structure, effectively reduce the depth of circuit breakers. And the use of composite structure, three-phase interrupter and associated charged body by the three independent phase separation of epoxy resin insulation casing, using a composite structure, the circuit breaker to meet the air under normal operating conditions from the required distance and climb and effectively reduce the size of circuit breakers, electrical circuit interrupter, a leading and dynamic and static conductive connection installed in the insulating tube, so that the distance only 300mm. All main circuit electrical connection fixed to connect with high reliability.

## 断路器型号、名称及含义

### Type of circuit breaker, the name and meaning

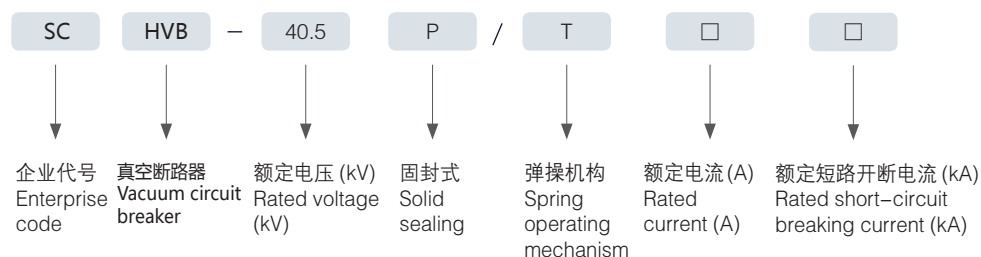

## 外形及安装尺寸

### General structure drawing and installation size

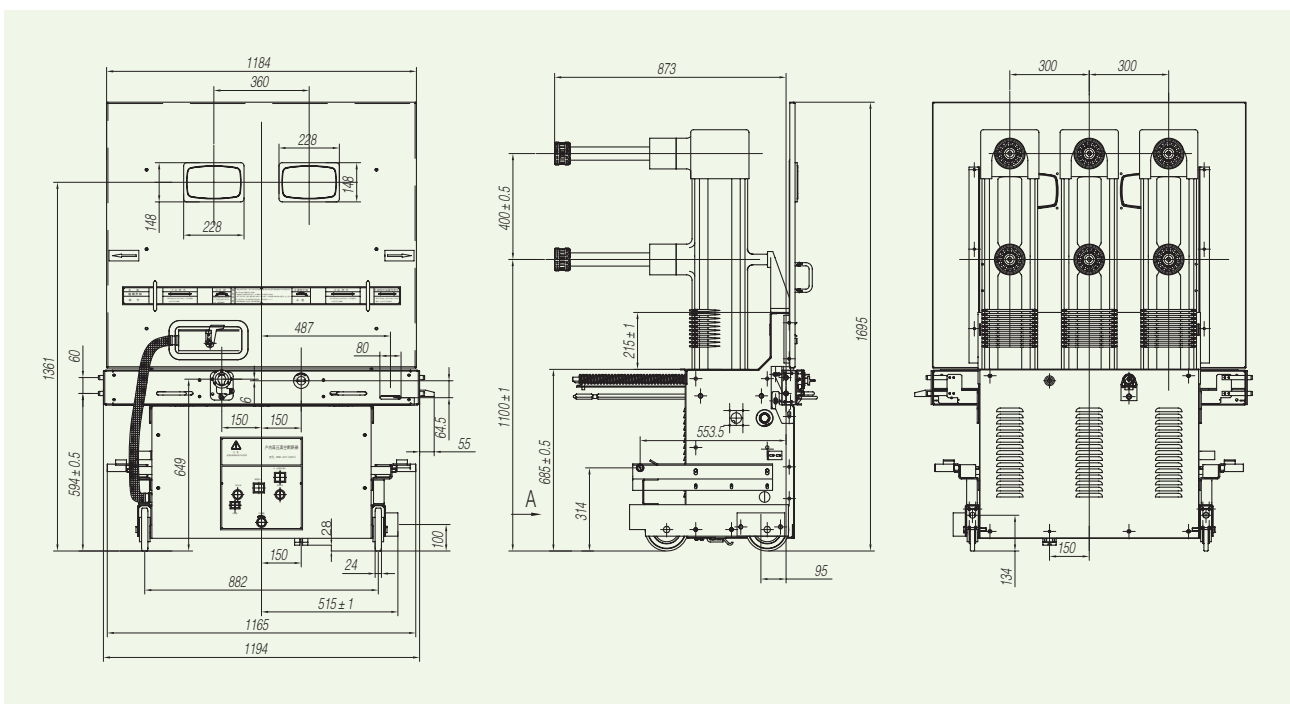

## 主要技术参数

### Mainly technical parameters

| 序号 No | 项目 Item                                                                       | 单位 Unit                                                                                                    | 技术参数 Technical parameters |      |           |      |
|-------|-------------------------------------------------------------------------------|------------------------------------------------------------------------------------------------------------|---------------------------|------|-----------|------|
| 1     | 额定电压 Rated voltage                                                            | kV                                                                                                         | 40.5                      |      |           |      |
| 2     | 额定电流 Rated current                                                            | A                                                                                                          | 1250                      | 1600 | 2000、2500 |      |
| 3     | 额定短路开断电流 Rated short-circuit breaking current                                 | kA                                                                                                         | 25                        | 31.5 | 25        | 31.5 |
| 4     | 动稳定电流 (峰值) Dynamic current (peak)                                             | kA                                                                                                         | 63                        | 80   | 63        | 80   |
| 5     | 4S 热稳定电流 4S thermal current                                                   | kA                                                                                                         | 25                        | 31.5 | 25        | 31.5 |
| 6     | 额定短路关合电流 (峰值) Rated short circuit making current (peak)                       | kA                                                                                                         | 63                        | 80   | 63        | 80   |
| 7     | 额定短路电流开断次数 Rated short-circuit current breaking times                         | 次 Times                                                                                                    | 20                        |      |           |      |
| 8     | 额定操作顺序 Rated operating sequence                                               |                                                                                                            | O-0.3s-CO-180s-CO         |      |           |      |
| 9     | 额定绝缘水平<br>Rated insulation level                                              | 1min 工频耐压 1min power frequency withstand voltage<br>雷电冲击耐压 (峰值) Lightning impulse withstand voltage (peak) | kV                        | 95   |           |      |
|       |                                                                               |                                                                                                            |                           | 185  |           |      |
| 10    | 机械寿命 Mechanical life                                                          | 次 Times                                                                                                    | 10000                     |      |           |      |
| 11    | 额定单个电容器组开合电流 Rated single capacitor device ON-OFF current                     | A                                                                                                          | 630                       |      |           |      |
| 12    | 额定背对背电容器组电流 Rated single back-to-back capacitor device current                | A                                                                                                          | 400                       |      |           |      |
| 13    | 储能电机额定电压 Rated voltage electrical energy storage                              | V                                                                                                          | AC、DC: 110; 220           |      |           |      |
| 14    | 储能电机额定功率 Energy Storage Power Rating                                          | W                                                                                                          | ≤ 230                     |      |           |      |
| 15    | 储能电机储能时间 Electrical Energy Storage Energy Storage time                        | S                                                                                                          | ≤ 15                      |      |           |      |
| 16    | 合分闸线圈额定电压 Hop Tripping coil rated voltage                                     | V                                                                                                          | DC: 110; 220              |      |           |      |
| 17    | 合分闸线圈额定电流 Hop Tripping coil rated current                                     | A                                                                                                          | 1.05(110V) 0.96(220V)     |      |           |      |
| 18    | 触头开距 Contactor opening distance                                               | mm                                                                                                         | 20 ± 2                    |      |           |      |
| 19    | 触头接触行程 Contactor Contact trip                                                 | mm                                                                                                         | 7.5 ± 1.5                 |      |           |      |
| 20    | 三相合分不同期性 At the different period of three consistency                         | ms                                                                                                         | ≤ 2                       |      |           |      |
| 21    | 触头合闸弹跳时间 Contact closing bounce time                                          | ms                                                                                                         | ≤ 3                       |      |           |      |
| 22    | 主回路电阻 (不包括触臂) Leading electrical circuit resistance (excluding contactor arm) | μ Ω                                                                                                        | ≤ 40                      |      |           |      |

# 手车式二次原理图

## Handcart secondary schematics

